

OWNER'S MANUAL

Model: UTV-45-7 (5302864)

(45 Gallon Lawn & Garden UTV Sprayer w/7-Nozzle Boom)

Technical Specifications

- 45 Gal. Corrosion-Resistant Polyethylene Tank
- Deluxe Pistol-Grip Handgun
- 25 Ft. Handgun Hose
- 26 Ft. max. vertical throw, 35 Ft. horizontal throw
- 7-Nozzle Boom Assembly (140" Spray Coverage)
- Adjustable Boom Height
- 12 Volt, 3.8 GPM Diaphragm Pump
- Multi-Lid to accurately measure and pour chemicals

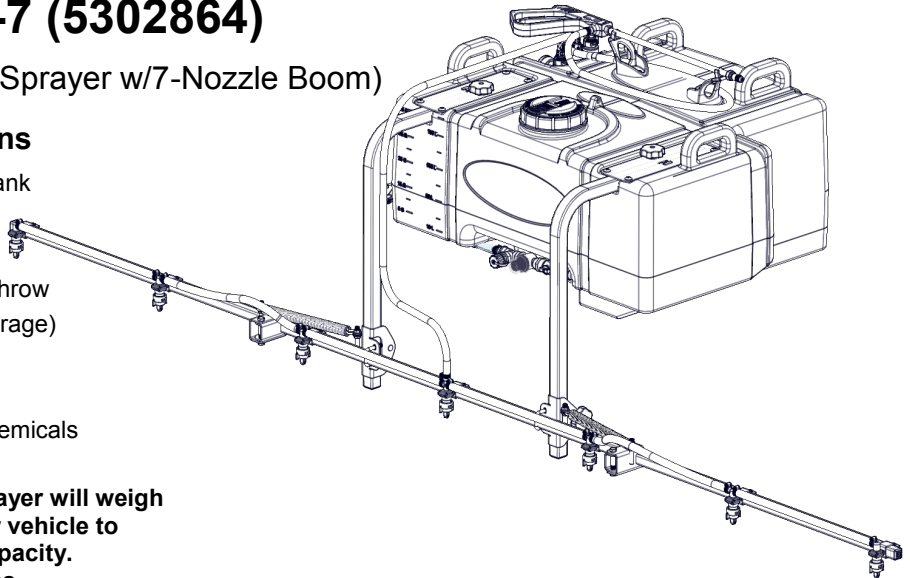

Caution: When fully filled with water, this sprayer will weigh 467 lbs.. Consult the owner's manual for your vehicle to verify that you are within it's load carrying capacity. Secure unit in your UTV, using tie-down straps (NOT INCLUDED)

Assembly Instructions

The sprayer is partially assembled at the factory. Follow the assembly instructions on page 2 and hook up the wiring to an existing 12 volt power source to complete your sprayer.

Connect the electrical hook-up to the end of your pump and clip the clips to a fully charged battery. The red wire must be connected to the positive (+) and the black wire should be connected to the negative (-).

Read the operating instructions and then run the sprayer using only water for testing. When everything tests all right, add the desired chemical mixture and water combination and start the spraying operation.

BEFORE RETURNING THIS PRODUCT FOR ANY REASON, PLEASE CALL

1-800-831-0027

IF YOU SHOULD HAVE A QUESTION OR EXPERIENCE A PROBLEM WITH YOUR FIMCO INDUSTRIES PRODUCT:

1-800-831-0027

BEFORE YOU CALL, PLEASE HAVE THE FOLLOWING INFORMATION AVAILABLE: SALES RECEIPT & MODEL NUMBER. IN MOST CASES, A FIMCO INDUSTRIES EMPLOYEE CAN RESOLVE THE PROBLEM OVER THE PHONE.

General Information

Thank you for purchasing this product. The purpose of this manual is to assist you in operating and maintaining your utility sprayer. Please read it carefully, as it furnishes information which will help you achieve years of trouble-free operation.

Warranty

Products are warranted for one year from date of purchase against manufacturer or workmanship defects for home owner usage and 90 days for commercial usage.

For technical assistance, visit our website @ www.fimcoindustries.com or call: **TOLL FREE @ 1-800-831-0027**

Our Technical Support Representatives will be happy to help you.

To obtain prompt, efficient service, always remember to give the following information...

- Correct Part Description and/or part number
- Model #/Serial # of your sprayer

Part descriptions and numbers can be obtained from the illustrated parts list section(s) of this manual.

*****IMPORTANT REMINDER*****

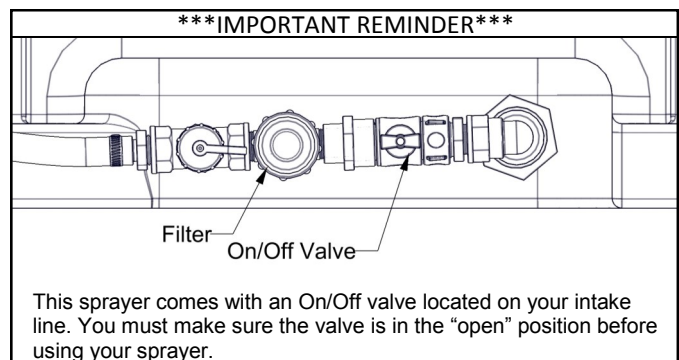

This sprayer comes with an On/Off valve located on your intake line. You must make sure the valve is in the "open" position before using your sprayer.



www.fimcoindustries.com

1000 FIMCO Lane, P.O. Box 1700, North Sioux City, SD 57049
Toll Free Phone: 800-831-0027 : Toll Free Fax: 800-494-0440

[5194332

(02/16)]

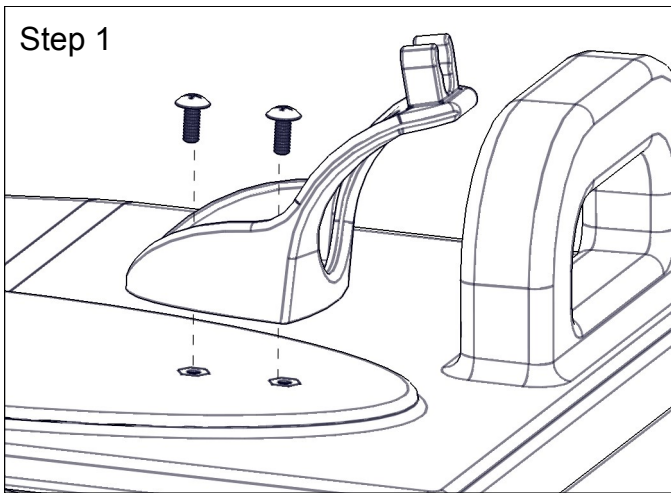

Step 1

Attach the (2) Hose Wraps to the top of the tank with (4) Phillips Head Screws

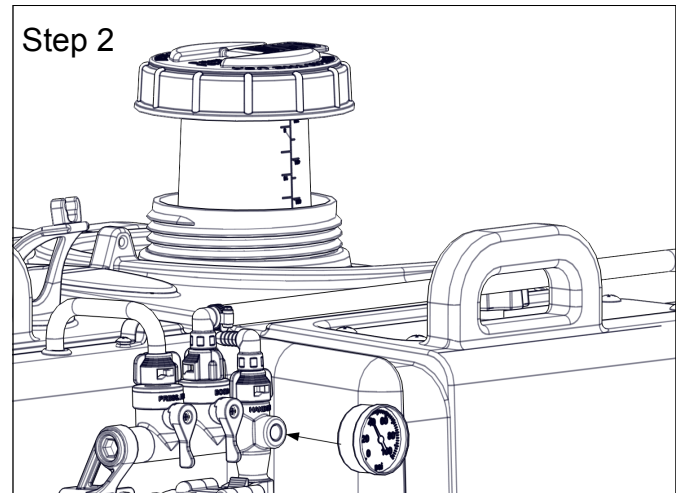

Step 2

Thread Pressure Gauge into open port on manifold., as shown.

Thread Multi-Lid on to tank.

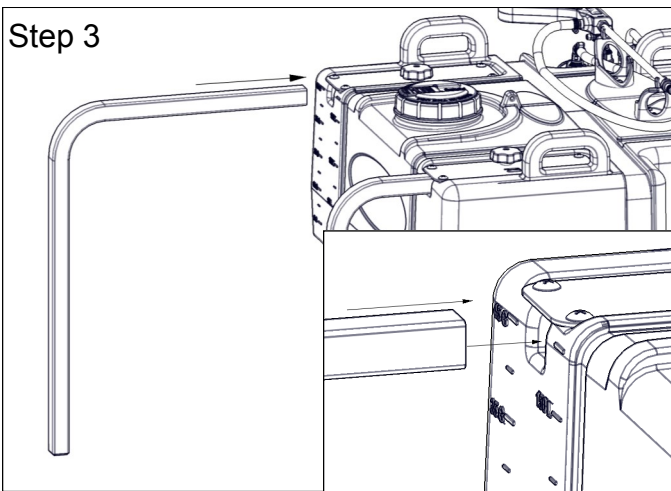

Step 3

With the unit in a UTV Box, slide the boom mount tubes in to the tank mounts and tighten the lobe knob.

* Secure tank using tie-down straps (NOT INCLUDED)

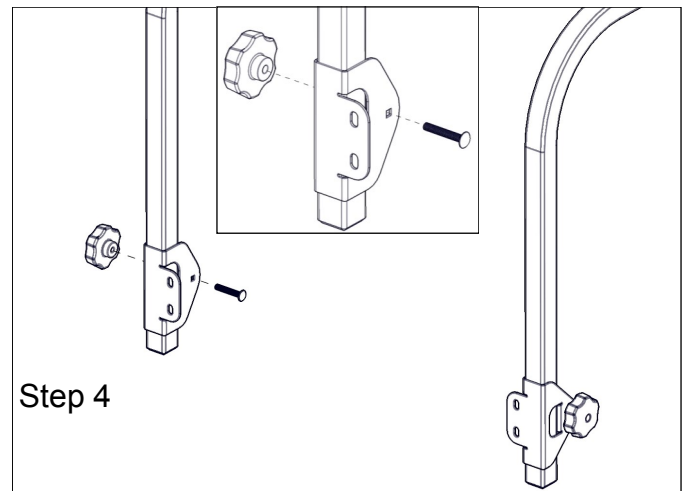

Step 4

Slide the boom clamps up the boom mount tubes and install the 1/4" carriage bolt and Lobe Knob., make sure the boom clamps are installed with the square carriage bolt holes or two boom mount holes to the inside and the lobe knob to the outside.

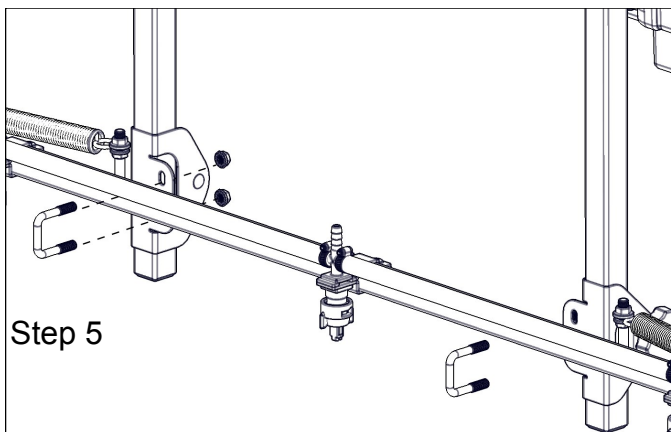

Step 5

Using the square U-bolts and nuts, attach the boom to the boom clamps.

Finally attach boom hose. Slip (2) 3/8" hose clamps onto hose. Attach one end of hose to the boom and the other end to the manifold. The boom hose can be cut to length if needed.

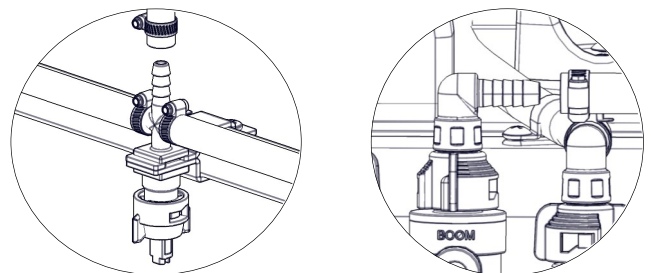

Once fully assembled, to remove the sprayer from a UTV Box, disconnect the boom supply hose from the manifold, using the quick connect fitting. Then loosen the two lobe knobs on the tank mounts and slide the boom out and set aside. Then the tank can be removed and set on the ground without damaging the tank or boom. The handles can be used to lift the empty tank in and out of the box. Tie down straps can be installed through the handles to secure the tank.

STOP WARNING STOP

DO NOT USE PUMP IN AN EXPLOSIVE ENVIRONMENT. DO NOT USE TO PUMP FLAMMABLE FLUIDS, GASOLINE, KEROSENE, FUEL, OIL, ETC.

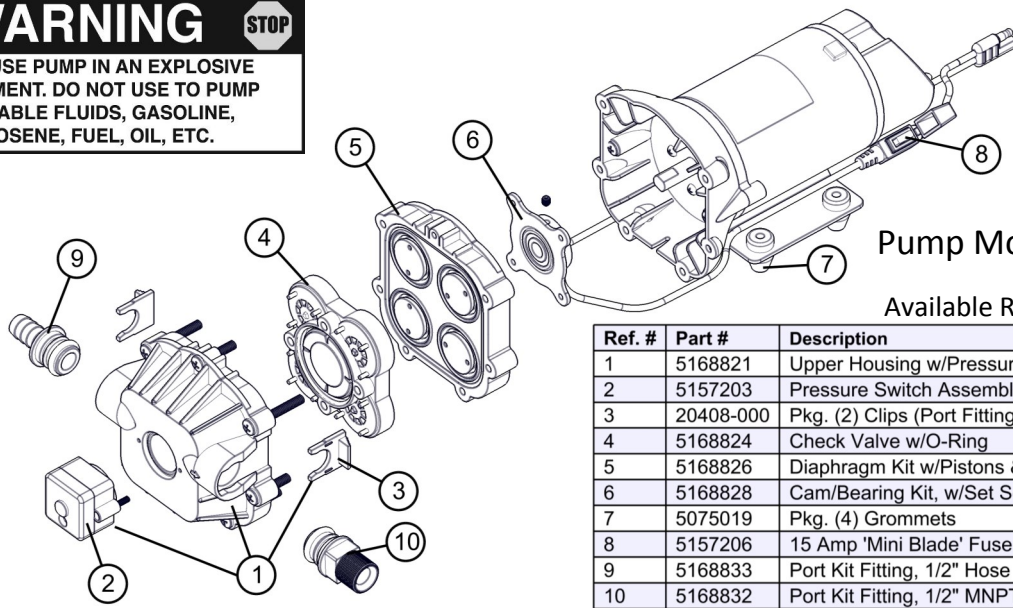

Pump Model: 5277982

Available Replacement Parts

Ref. #	Part #	Description	Qty
1	5168821	Upper Housing w/Pressure Switch	1
2	5157203	Pressure Switch Assembly	1
3	20408-000	Pkg. (2) Clips (Port Fitting)	1
4	5168824	Check Valve w/O-Ring	1
5	5168826	Diaphragm Kit w/Pistons & (4) Screws	1
6	5168828	Cam/Bearing Kit, w/Set Screw	1
7	5075019	Pkg. (4) Grommets	1
8	5157206	15 Amp 'Mini Blade' Fuse	1
9	5168833	Port Kit Fitting, 1/2" Hose Barb	1
10	5168832	Port Kit Fitting, 1/2" MNPT	1

DO

- Clean and rinse your pump after each use with Fimco Tank Neutralizer
- Winterize your pump or sprayer by rinsing, draining and running RV Antifreeze through it before storing for the winter.
- Use clean water for your spray mixture
- Store inside a building when not in use.

DON'T

- Use to pump bleach.
- Use to pump petroleum products such as diesel fuel, gasoline or kerosene
- Leave your pump sit with spray mixture in it for extended periods
- Use dirty or unfiltered water for spraying

CAUTION

PRESSURE SWITCH OPERATION

Pressure switch is pre-set at the factory. Improper adjustment of the pressure switch, may cause severe overload or premature failure. If the pump is subjected to rapid cycling during normal operation, or infrequent periods, damage may occur.

Troubleshooting the Pump:

Motor does not run:

- Check for loose wiring connection(s).
- Make sure the 'ON/OFF' switch in the lead wire assembly is in the 'ON' position. "I" is the 'ON' position and 'O' is the 'OFF' position.
- Check for defective pressure switch. Make sure you are connected to a good 12 volt power source. Make sure any on/off switches are in the 'on' position.
- Remove the cap to the pressure switch. Pull both red wires off of their terminals, and touch the two ends together. If your pump runs when you do this, your pressure switch will need to be replaced.
- Check the fuse.
- Check for low voltage at the power supply.

Pump does not prime:

- Check for air leaks in supply line.
- Check for debris in the check valve assembly.
- Check for defective check valve.
- Check for clogged strainer/filter.
- Check for cracks in the pump housing.
- Check for empty product supply.

Pulsating flow (surging):

- Check for defective pressure switch.
- Check for leaks in the discharge line.
- Check for restriction in the discharge line.
- Check for debris in nozzle orifice.
- Discharge hose may be too long.
- Check for clogged strainer.

Motor continues to run after discharge is shut off:

- Check for empty product supply.
- Check for open bypass valve. (if equipped)
- Check for low voltage.
- Check for leak in discharge line.
- Check for defective or dirty check valve.
- Check for defective pressure switch.

Current:	7.4 Amps @ 40 PSI
Check Valve:	Viton
Wetted Parts Housing:	Polypropylene
Diaphragm:	Santoprene
Liquid Temperature:	130° F max.

GPM=Gallons Per Minute
PSI=Pounds per Square Inch
DC=Direct Current

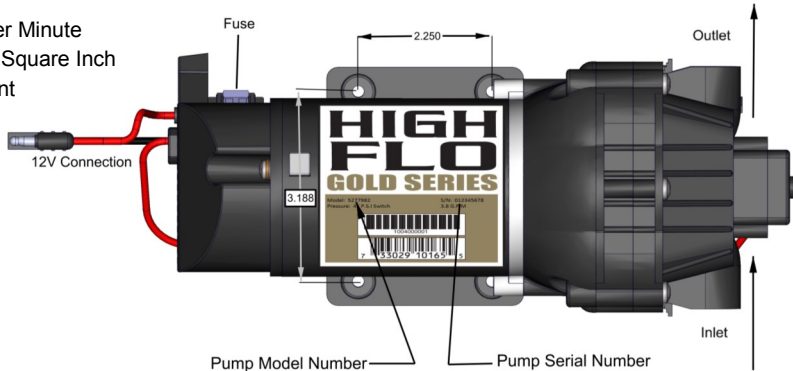

Testing the Sprayer

NOTE: It is important that you test your sprayer for leakage and proper spray patterns with plain water before chemical application is attempted. This will also give you the opportunity to familiarize yourself with the operation of the sprayer.

Add water to the tank and drive to the starting place for spraying. When you are ready to spray, position booms for spraying and turn the boom valve to the "on" position. This will start solution spraying from the tips of the boom. The pressure will decrease slightly when the boom is spraying. Adjust the pressure by turning the "ON/OFF" valve lever on the bypass line valve.

Read the operating instructions and initially begin spraying by closing the 'bypass' valve and opening the boom line valve. This will enable the air in the line to be eliminated (purged) through all the tips, while building pressure. When everything tests all right (no leaks and good pressure), add the desired chemicals to the mixture and water combination and start your spraying operation. Adjust the pressure and spray as you did in the testing procedure.

Conditions of weather and terrain must be considered when setting the sprayer. Do not spray on windy days. Protective clothing must be worn in some cases

Be sure to read the chemical label(s) before application!

Operation

The pumping system draws solution from the tank, through the strainer and to the pump. The pump forces the solution under pressure to the handgun or boom nozzles.

Connect the lead wire to a fully charged 12 volt battery. You may use either a stand-alone battery or the battery on your towing vehicle. The lead wire has an On/Off switch to activate the pump. "-" is on and "O" is off.

Fill the tank part way with water and then add the desired amount of chemical to be sprayed. Finish filling tank to proper level. Turn the pump on and by depressing the "-" side of the rocker switch. The pump is equipped with a pressure switch that is pre-set at the factory to shut the pump off when all discharges are closed.

The pump will turn back on when one of the following actions occurs: the handgun lever is squeezed to spray the handgun, or the boom valve is opened to broadcast spray with the boom, or the bypass valve is opened to re-circulate solution back into the tank.

When spraying with either the boom or the handgun, pressure may be reduced by slowly opening the bypass valve until desired pressure is achieved. Opening the valve decreases pressure, closing the valve increases pressure. When spraying with the boom, the proper method to set the pressure is to open the boom valve completely and if a lower pressure is desired, then slowly open the bypass valve until that pressure is obtained.

For the safest and most efficient chemical application, you will need to calibrate your sprayer using the tip and speed charts. Once you have determined the proper speed and pressure settings, you will need to consult your chemical label for the amount of chemical to be added to the tank. Read the entire label. Use only according to label directions.

The nozzles on the boom will spray an 140 inch wide swath. Check the nozzle pattern by spraying water on a concrete surface.

Calibration

Chemical labels may show application rates in gallons per acre, gallons per 1000 square feet or gallons per 100 square feet. You will note that the tip chart shows 2 of these rating systems. Once you know how much you are going to spray, then determine (from the tip chart) the spraying pressure (PSI), and the spraying speed (MPH).

Determining the proper speed of the pulling vehicle can be done by marking off 100, 200 & 300 feet. The speed chart indicates the number of seconds it takes to travel the distances. Set the throttle and with a running start, travel the distances. Adjust the throttle until you travel the distances in the number of seconds indicated by the speed chart. Once you have reached the throttle setting needed, mark the throttle location so you can stop and go again, returning to the same speed.

Add water and proper amount of chemical to the tank and drive to the starting place for spraying.

Using the Boom Nozzles

Four things must be considered before spraying with the boom.

1. How much chemical must be mixed in the tank.
 2. Rate of spray (gallons per acre to be sprayed).
 3. What pressure (p.s.i.) will be used.
 4. Speed traveled (mph) while spraying.
- * Refer to the chemical label to determine your chemical mixture
 - * See the tip chart to determine the pressure to be used. The chart will also show the speed used when spraying.
 - * Start the pump and open the valve to the boom nozzles.
 - * Check the spray pattern. Usually you can see the coverage better on a solid concrete surface, such as a driveway.
 - Raise or lower the nozzles so that you will have a good coverage pattern. Generally the proper height

Speed Chart			
	Time Required in seconds to travel a distance of		
Speed in M.P.H. (Miles Per Hour)	100 Ft.	200 Ft.	300 Ft.
1.0	68 sec.	136 sec.	205 sec.
2.0	34	68	102
3.0	23	45	68
4.0	17	34	51
5.0	14	27	41
6.0	11	23	34
7.0	9.7	19	29
8.0	8.5	17	26
9.0	7.6	15	23
10.0	6.8	14	20

Spray Tip Rate Chart (20" Spacing)											
Tip No.	Spray Height	Pressure (psi)	Capacity (GPM)	Gallons Per Acre - Based on Water							
				1 MPH	2 MPH	3 MPH	4 MPH	5 MPH	6 MPH	8 MPH	
AIXR11002VP	18"	15	.12	35.6	17.8	11.8	8.9	7.1	5.9	4.5	
		20	.14	41.6	20.8	13.8	10.4	8.3	6.9	5.2	
		30	.17	50.4	25.2	16.8	12.6	10.1	8.4	6.3	
		40	.20	59.6	29.8	19.8	14.9	11.9	9.9	7.4	
Tip No.	Spray Height	Pressure (psi)	Capacity (GPM)	Gallons Per 1000 Sq. Ft. - Based on Water							
				1	2	3	4	5	6	8	
AIXR11002VP	18"	15	.12		.41	.27	.20	.16			
		20	.14		.48	.32	.24	.19			
		30	.17		.58	.39	.29	.23			
		40	.20		.68	.45	.34	.27			

Maintenance During/After Spraying

Periodically check the strainer and clean the screen on your intake line. Proper care and maintenance will prolong the life of your sprayer.

After use, fill the sprayer half way with clean water. Start the pump and allow the water to pump through the entire plumbing system and nozzles. Drain and then refill half full, add the recommended amount of a good quality tank cleaner, such as FIMCO Tank Neutralizer and Cleaner. (If no tank cleaner is available, you may substitute dish soap for this step). Turn pump on and circulate through system for 15 minutes and then spray out through boom and handgun nozzles. Refill sprayer half way with clean water and repeat. Follow the chemical manufacturer's disposal instructions of all wash or rinsing water. If boom or handgun nozzles need cleaning, remove them from the sprayer and soak in warm soapy water. Clean with a soft bristled brush or toothpick if necessary. Never use a metal object. Even the slightest damage can change the flow rate and spray distribution. Water rinse and dry the tips before storing.

WARNING: Some chemicals will damage the pump valves if allowed to soak untreated for a length of time! **ALWAYS** flush the pump as instructed after each use. **DO NOT** allow chemicals to sit in the pump for extended times of idleness. Follow the chemical manufacturer's instructions on disposal of all waste water from the sprayer.

Winter Storage

Before storing your sprayer for winter or long term storage, thoroughly clean and drain it as much as possible. Then pour enough pink RV antifreeze into the tank so that when the pump is turned on you can pump the antifreeze throughout the entire plumbing system, including the bypass. Make sure to operate the boom and handgun until you see pink fluid spraying from the nozzles. Leave any remaining antifreeze in the tank. Before your next usage, rinse the antifreeze from the sprayer with clean water.

It is nearly impossible to drain all of the water from the sprayer and any trapped water can freeze in cold weather and damage parts of the sprayer. Pumping the antifreeze through the system will displace the water and help prevent this damage.

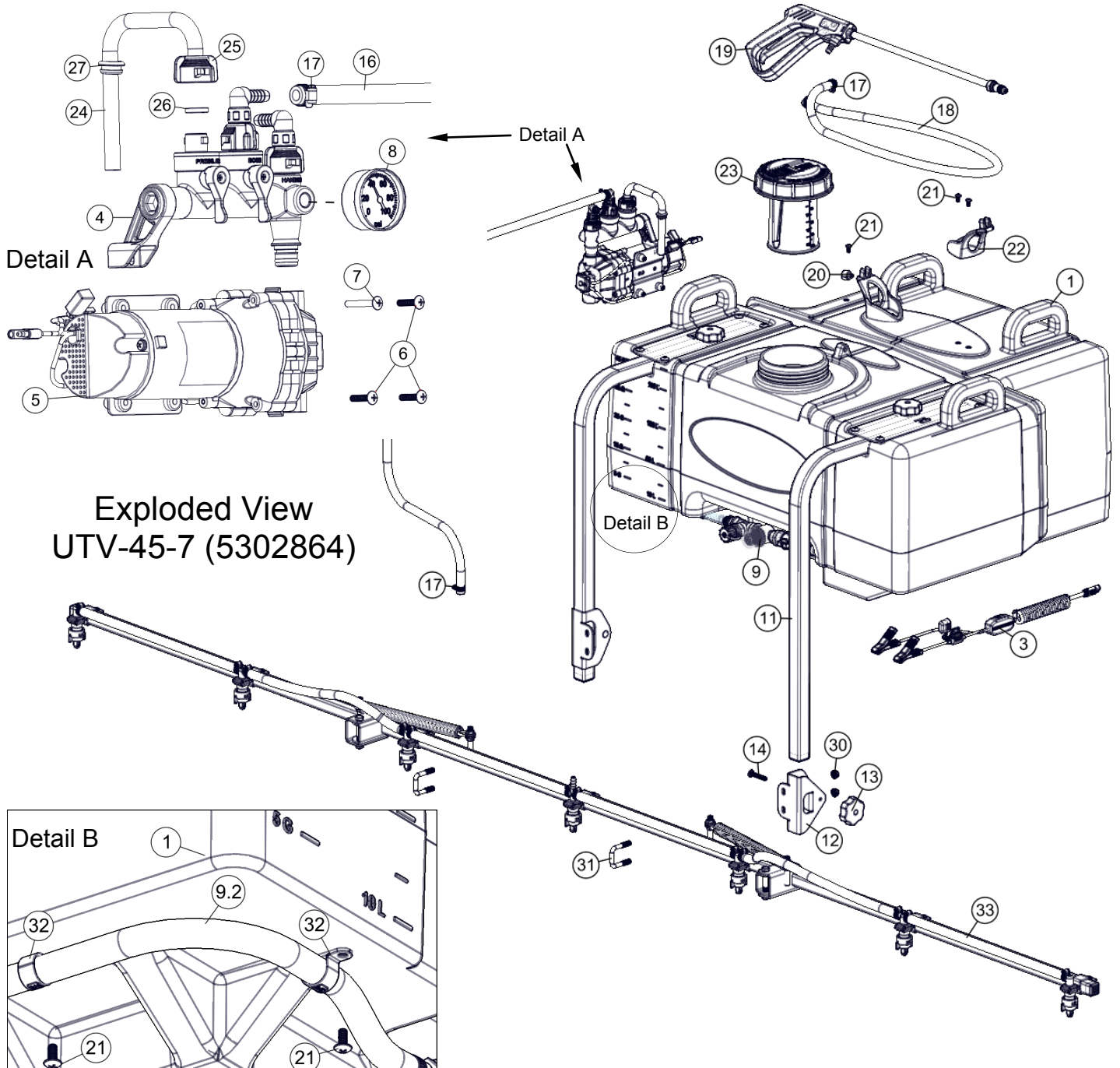

Parts List: UTV-45-7 (5302864)

Ref. #	Part #	Description	Qty
1	5169329	45 Gallon UTV Tank	1
2	TF50DTN	Polypro 1/2" Bulkhead Fitting	1
3	5278114	Lead Wire Assembly w/15A Fuse & 30A Clips (96" Long)	1
3.1	5157238	15 Amp Regular Blade Fuse	1
4	5278714	Quick Connect Manifold Assembly	1
4.1	5302347	Quick Connect Manifold	1
4.2	5143422	QC Manifold - Support Bracket	1
4.3	5302802	QC Manifold 3/8 Swivel 90° Elbow Assembly	2
5	5277982	Hi Flo Gold Series 3.8 GPM Pump	1
6	5117168	#10-24 x 1" Phillips Truss Head Machine Screw	3
7	5117338	#10-24 x 1 1/2 Long Truss Head Machine Screw	1
8	5167097	2" Dry 100# Back Mount Gauge	1
9	5278928	45G UTV Intake Plumbing	1
9.1	5278717	UTV Intake Plumbing	1
9.1.1	5067131	Poly Fitting, 1/2" MNPT x 1/2" HB	1
9.1.2	5010230	Poly Tee, 1/2" FNPT	1
9.1.3	5005195	Poly Adapter, 1/2" MNPT x 3/4" MGHT	1
9.1.4	5274373	Drain Plug Cap, Tether, and Washer Assembly	1
9.1.5	5116417	Nylon 'TEE' Line Strainer (1/2" MNPT, 50 Mesh)	1
9.1.5.1	5046086	Strainer Cap	1
9.1.5.2	5072356	Strainer Gasket	1
9.1.5.3	5116177	Screen	1
9.1.5.4	5058072	Strainer Bowl	1
9.1.6	5005190	Poly Adapter Coupler, 3/4" FGHT x 1/2" FNPT	1
9.1.7	5016066	Garden Hose Washer	1
9.1.8	5143419	Swivel Shut-Off	1
9.2	5020578	1/2" Polyspring Hose X 31"	1
9.3	5051114	Hose Clamp, 1/2"	2
9.4	5168833	Port Kit Fitting, 1/2" Hose Barb	1
10	5278715	UTV Boom Mount	2
10.1	5095394	Tank Boom Mount	1

Ref. #	Part #	Description	Qty
10.2	5095393	Boom Clamp	1
10.3	5088026	5 Lobe Knob 1/4-20UNC	1
10.4	5034527	1/4-20nc x 1.5" Carriage Bolt	1
11	5278716	UTV Boom Tube Assembly	2
11.1	5095395	UTV Boom Mount	1
11.2	5046448	Square Cap, Black (1-1/4" x 14 Ga. Square Tube)	2
12	5051151	Boom Clamp	2
13	5088026	5 Lobe Knob 1/4-20UNC	2
14	5034807	1/4-20nc X 1.75" Carriage Bolt	2
15	5117342	5/16"-18 x 1/2" Phillips Truss Head Machine Screw	8
16	5020127	Hose, 3/8"-1 Brd. x 72"	1
17	5051144	Hose Clamp, 3/8"	4
18	5020527	Hose, 3/8"-1 Brd. x 25 Ft.	1
19	5273959	Deluxe Pistol-Grip Handgun w/X-26 Tip	1
19.1	5018331	Brass Handgun Tip (X-26)	1
20	5051122	5/8" Black Nylon Loom Cable Clamp	1
21	5117234	#10-24 x 1/2" Phillips Truss Head Machine Screw	7
22	5133276	30 Gal Hose Wrap	2
23	5058200	32 oz -1000 ml Multi-LID Complete Assembly	1
24	5149157	Rigid By-Pass Tube Assembly	1
25	5143429	QC Manifold - QC Quarter Turn Cap	1
26	5143430	Flat Washer - Hose Barb Seal	1
27	5075018	Grommet, 1/2" I.D.	1
28	5005195	Poly Adapter, 1/2" MNPT x 3/4" MGHT	1
29	5010243	Poly Street Elbow, (90 Deg) 1/2" MNPT x 1/2" FNPT	1
30	5006307	5/16-18nc Hex Flanged Whiz Nut Gr. 5	4
31	5034159	Square U-Bolt, 5/16" x 1 5/16" x 1 7/8"	2
32	5051152	3/4" Black Nylon Loom Clamp	2
33	5301897	7-Nozzle Boom Assembly	1

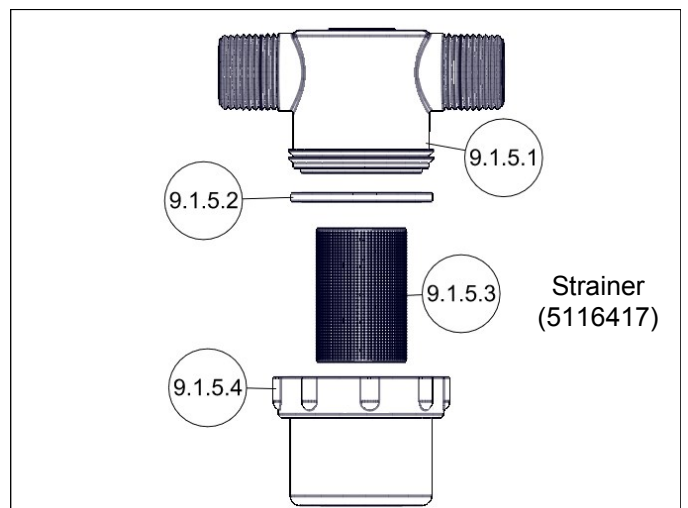
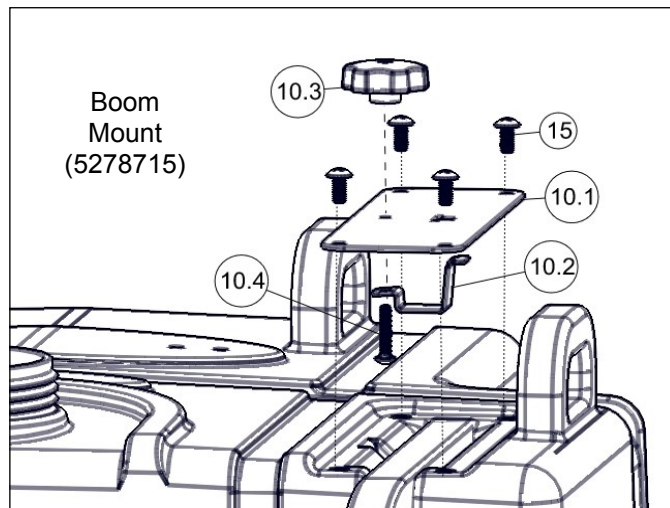
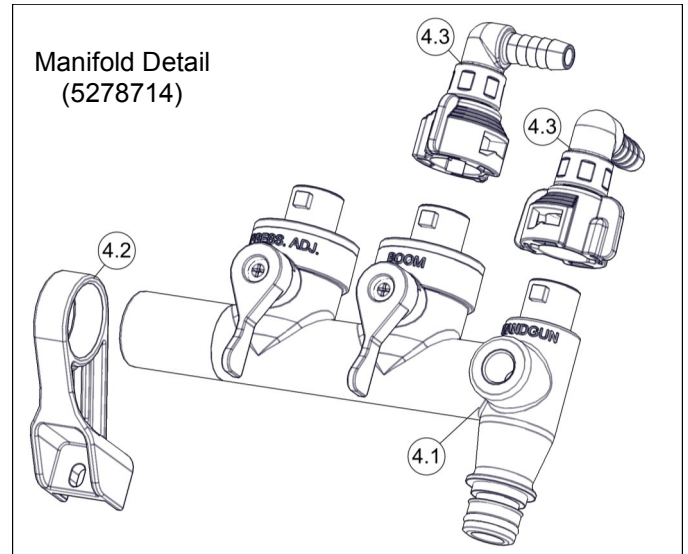
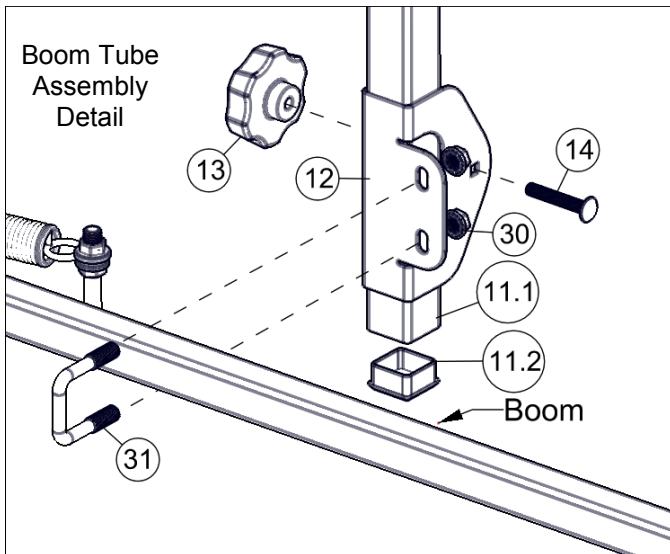

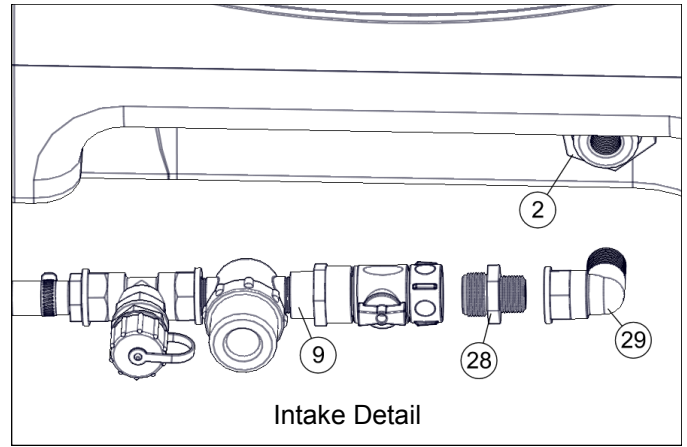
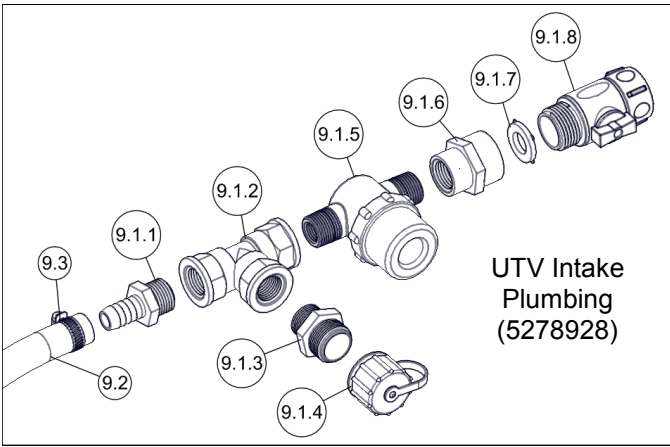

**7-Nozzle (Standard) Boom Assembly
(with 3/8" Hose, 1" Sq. Tubing & AIXR11002VP Tips)**

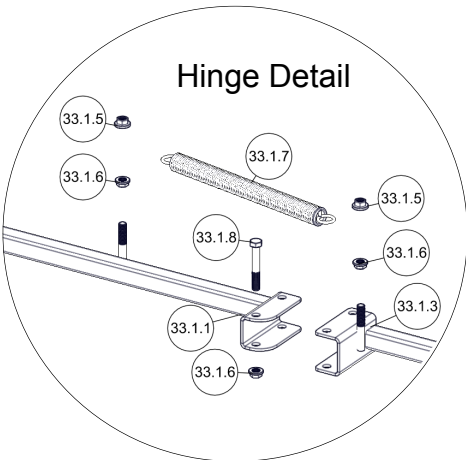
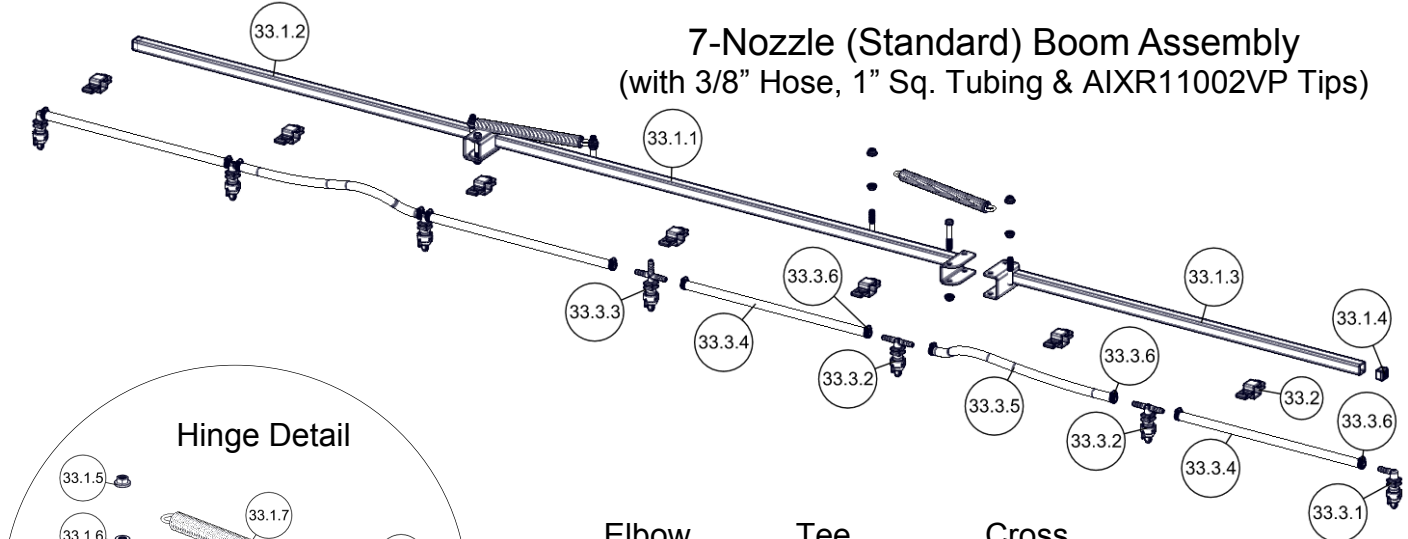

Elbow

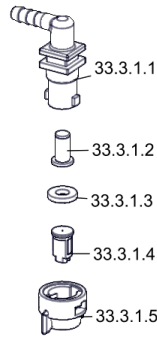

Tee

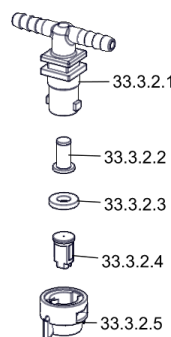

Cross

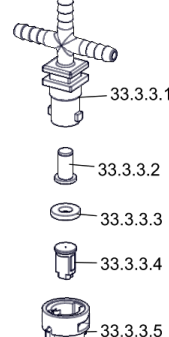

**Clamp
Bag of 7: 5277730**

Ref. #	Part #	Description	Qty
33	5301897	7-Nozzle Boom Assembly	1
33.1	5277780	7-Nozzle Boom	1
33.1.1	5277838	Center Boom Weldment 1" Sq. Tube	1
33.1.2	5277837	Outer Boom Weldment (LH) (1" Sq Tube)	1
33.1.3	5277836	Outer Boom Weldment (RH) (1" Sq Tube)	1
33.1.4	5046106	Square Cap, Black (1" Square Tube)	2
33.1.5	5006259	3/8"-16 Hex Whiz (Flange) Locknut	4
33.1.6	5006345	3/8"-16 Flange Locknut (Grade F)	6
33.1.7	5019228	Extension Spring	2
33.1.8	5034169	H.H.C.S., 3/8"-16 x 2 1/2"	2
33.2	5277923	Vari-Quick Clamp (1" Sq. Tube)	7
33.3	5277696	7-Nozzle Harness (3/8")	1
33.3.1	5277689	"ELL" Nozzle Sub-Assembly (3/8")	2
33.3.1.1	5056113	Single Hose Shank (3/8" Hose)	1
33.3.1.2	5116019	Nozzle Strainer, Red (50 Mesh)	1
33.3.1.3	5016157	Seat Washer (QJ Caps)	1
33.3.1.4	5018371	Air-Induction XR Flat Spray Tip (AIXR11002VP)	1

Ref. #	Part #	Description	Qty
33.3.1.5	5046219	Quick TeeJet Cap ONLY (Yellow)	1
33.3.2	5277690	"TEE" Nozzle Sub-Assembly (3/8")	4
33.3.2.1	5056114	Double Hose Shank (3/8" Hose)	1
33.3.2.2	5116019	Nozzle Strainer, Red (50 Mesh)	1
33.3.2.3	5016157	Seat Washer (QJ Caps)	1
33.3.2.4	5018371	Air-Induction XR Flat Spray Tip (AIXR11002VP)	1
33.3.2.5	5046219	Quick TeeJet Cap ONLY (Yellow)	1
33.3.3	5277691	"Cross" Nozzle Sub-Assembly (3/8")	1
33.3.3.1	5056115	Triple Hose Shank (3/8" Hose)	1
33.3.3.2	5116019	Nozzle Strainer, Red (50 Mesh)	1
33.3.3.3	5016157	Seat Washer (QJ Caps)	1
33.3.3.4	5018371	Air-Induction XR Flat Spray Tip (AIXR11002VP)	1
33.3.3.5	5046219	Quick TeeJet Cap ONLY (Yellow)	1
33.3.4	5020510	Hose, 3/8"-1 Brd. x 19-3/8"	4
33.3.5	5020347	Hose, 3/8"-1 Brd. x 21"	2
33.3.6	5051144	Hose Clamp, 3/8"	12

Technical Specifications

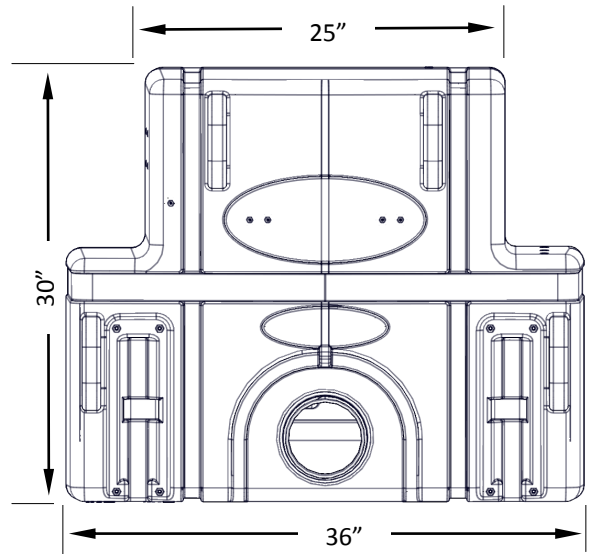
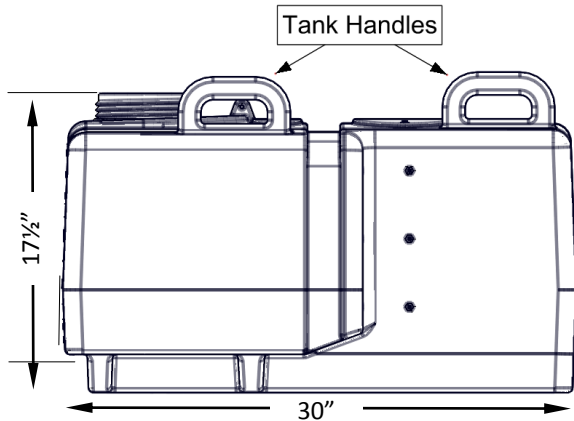

- ◆ Properly secure the tank to your utility vehicle, using tie-down or ratchet straps (Not Included).
- ◆ Tank straps may be installed through the handles to help prevent straps from slipping off tank if too loose.
- ◆ Handles can be used to lift the empty tank in and out of the box.
- ◆ Stay within your utility vehicle's weight limits. This unit when filled with water weighs approximately: 467 lbs. Consult the owner's manual for your vehicle.

There is a nylon shut-off valve on the intake line. It is at this location so you can shut off the flow of solution to access your system's filter screen for cleaning.

Checking/Cleaning the sprayer's filter/screen:

- ◆ Start your pump and before it shuts off, reach down and Shut the nylon valve to the 'Closed' position (lever is perpendicular to the flow of fluid), then shut off your pump.
- ◆ Unscrew the bowl of the filter to access the screen.
- ◆ Remove the screen and clean as necessary. Replace when done and reassemble the entire assembly.
- ◆ Make sure the valve is turned to the 'Open' position before restarting your pump.

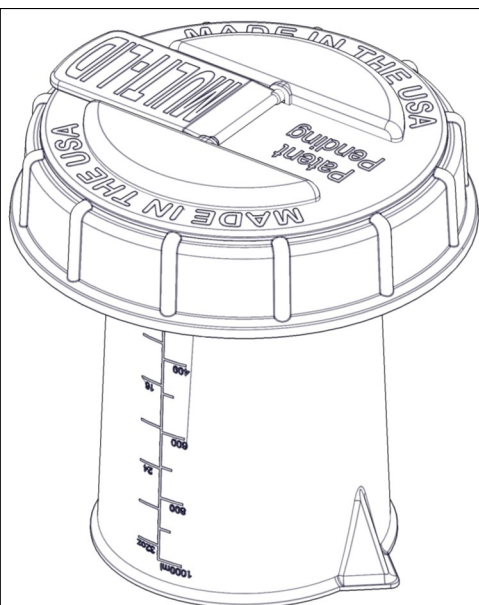
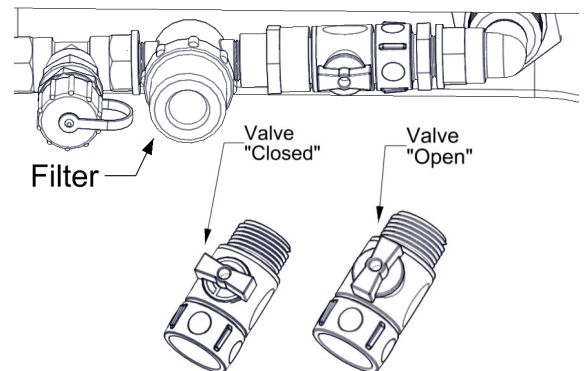

Multi-Lid Directions

1. Open fill cap and place garden hose into tank. Fill tank to desired gallon marker, if marker is above the bottom of calibration container, stop before water reaches calibration container. This is done to help chemical mix better and keep foaming of chemical to a minimum later.
2. Remove Multi-Lid and use calibration container to measure the correct amount of chemical for the water being used.
3. Pour chemical into tank and tighten Multi-Lid back onto tank. If desired amount of water was added in step 1, you are done. Be sure to press firmly on fill cap to seal with Multi-Lid. If desired amount of water was not met in step 1, proceed to step 4.
4. Open fill cap and place garden hose into tank. Add water to the desired gallon marker. Close fill cap, pressing firmly to seal cap to Multi-Lid.

NOTE: If water and chemical has not mixed properly, use the pressure adjustment control on the manifold to recirculate the mixture through tank.